

KAM ELEC AIR

**Elettrico-Electric-Électriques
Elektrische-Eléctrico-Elctrice**

IRA03418
Istruzioni di montaggio ed uso
Operation instructions
Instructions de montage et usage
Montage- und Bedienungsanleitung
Instrucciones de montaje y uso
Instrucțiuni pentru montare și utilizare

IRSAP

creating your comfort

IRSAP SPA
45031 Arquà Polesine (RO) Italy
Tel. +39 0425 466611 - Fax +39 0425 466662
Website: <http://www.irsap.com>
E-mail: info@irsap.it

IR GROUP SARL
19,Chemin de la Plaine 69390 Vourles (France)
Tel. +33 04 28 00 01 67 - Fax +33 04 72 31 86 40
Web: <http://www.irsap.com>;
E-mail: irsaphross@irgroup.fr

IRSAP IBERICA S.L.
Oficina y Almacén: P.I.CAMI RAL
Leonardo da Vinci,4 08850 Gavà (Barcelona)
Tel. 93 633 47 00 - Fax 93 633 47 04
E-mail: informacion@irsap.com
Web: www.irsap.com

IRROM Industrie S.R.L.
Str. Pricipală 1/A, Sat Fundătara, Iclod 407336,
jud. Cluj, România
Tel: +40 (0)264 263400 - Fax: +40 (0)264 263404
Web: www.irsap.ro

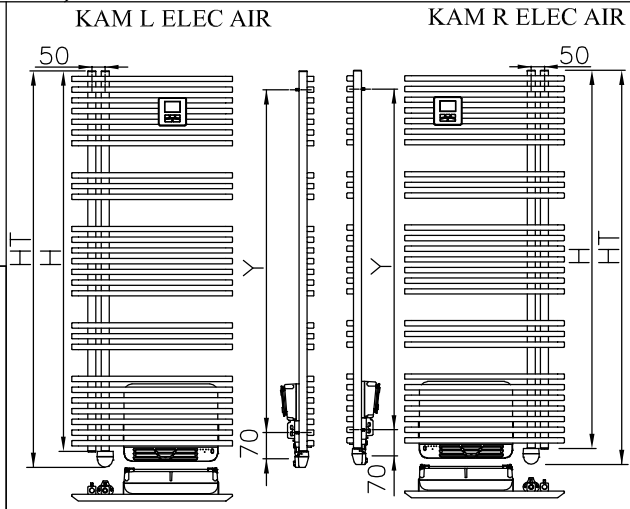
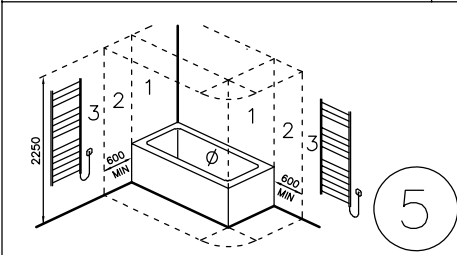
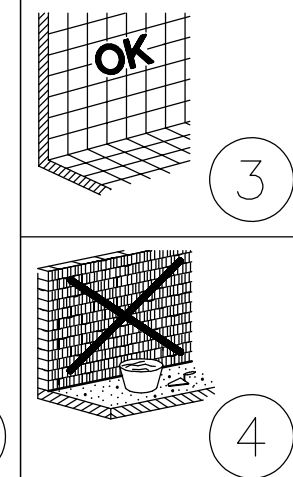
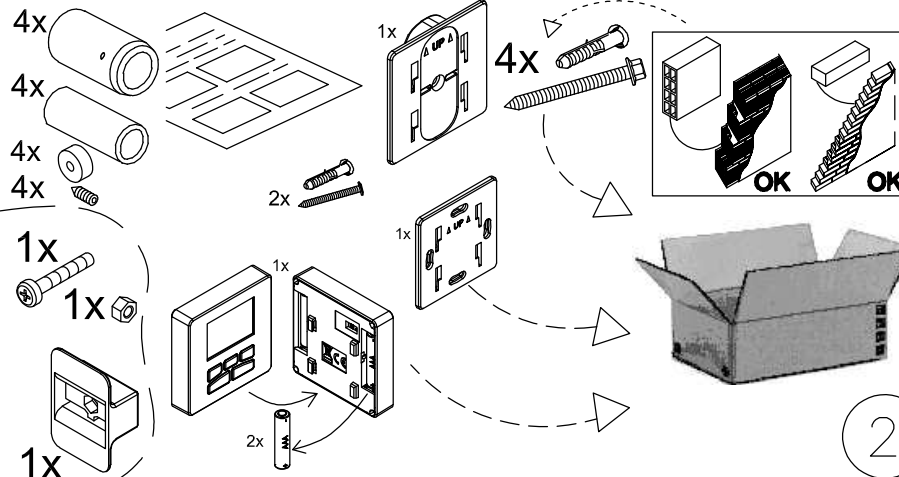
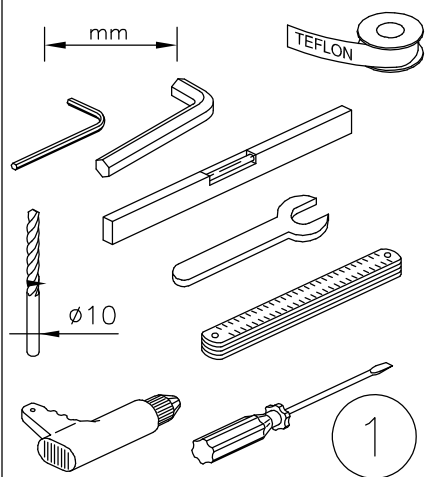

HT	H	Y
920±2	860±2	720
1480±2	1420±2	1280
1960±2	1900±2	1760

(*):
ESEMPIO CON RADIATORE KAM L
EXEMPLE AVEC RADIATEUR KAM L
EJEMPLO CON RADIADOR KAM L
EXAMPLE WITH KAM L RADIATOR
BEISPIEL MIT HEIZKÖRPER KAM L
EXEMPLU CU CALORIFERUL KAM L

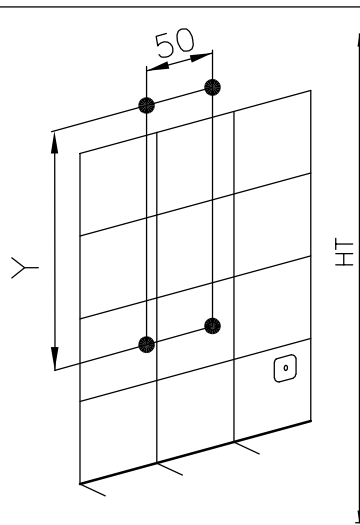
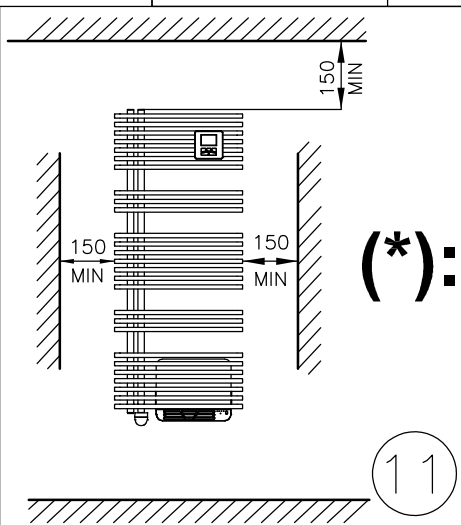
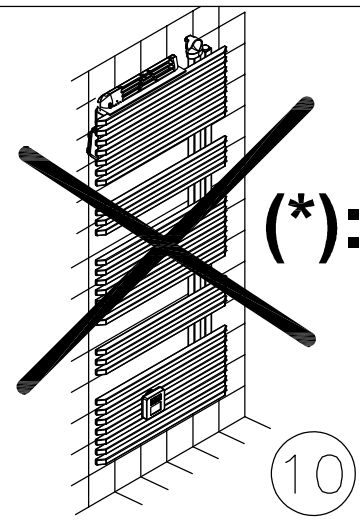
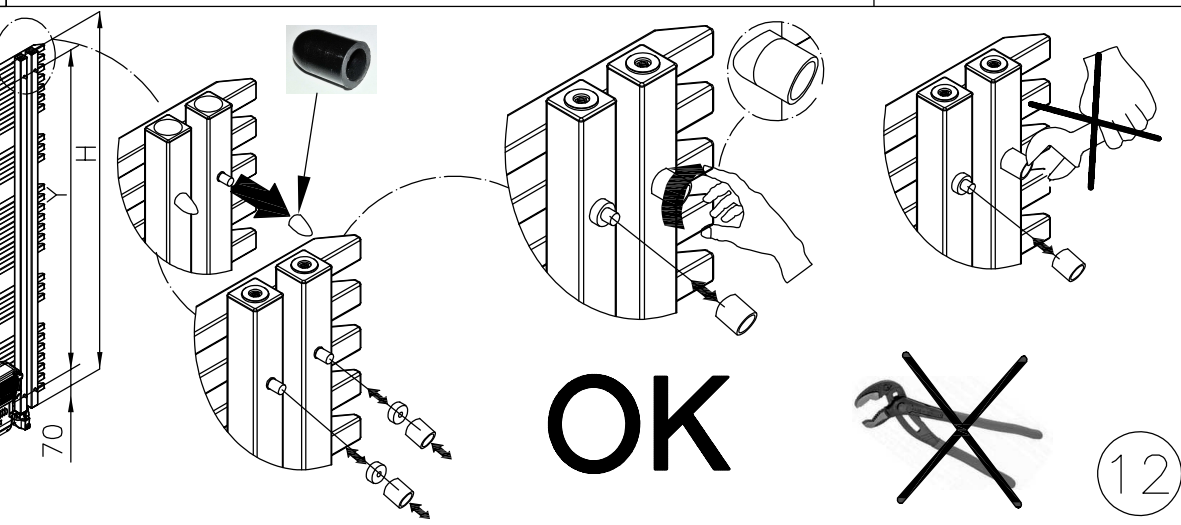
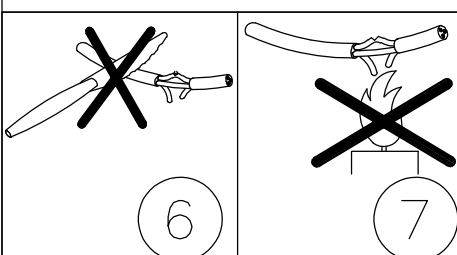
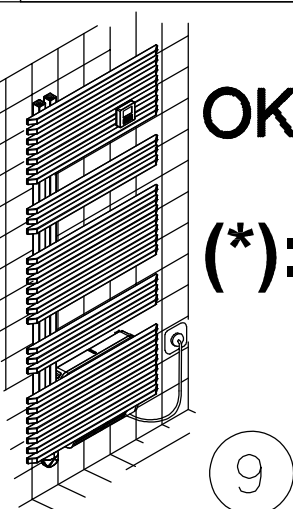

HT	H	Y
920±2	860±2	720
1480±2	1420±2	1280
1960±2	1900±2	1760

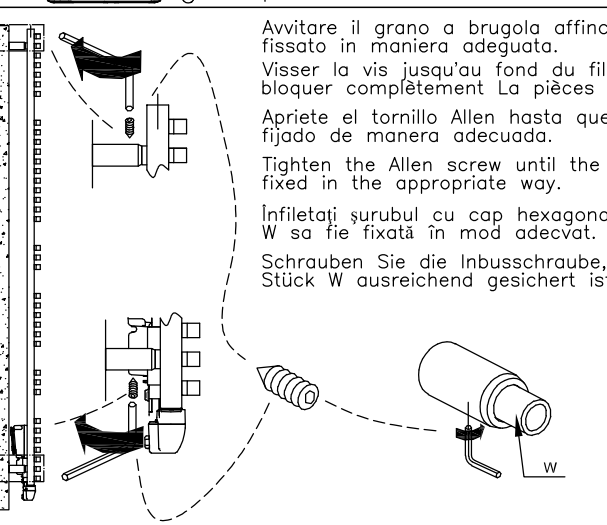
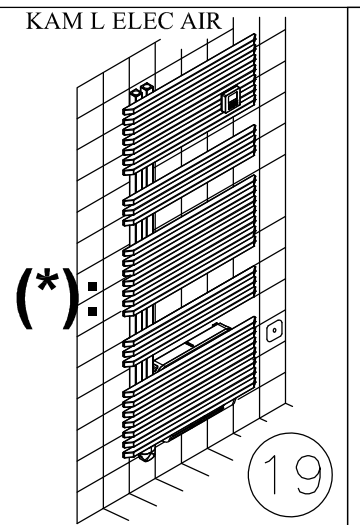
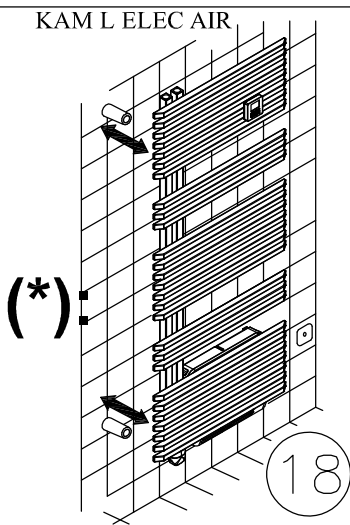
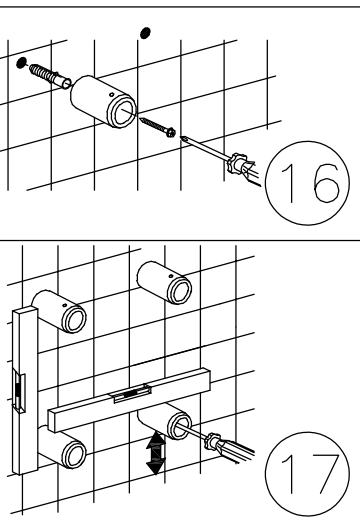
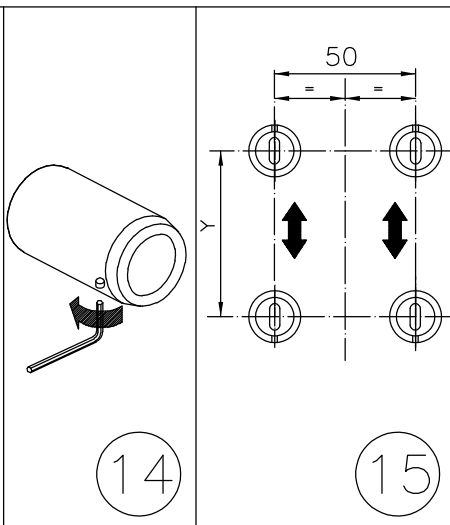

Avvitare il grano a brugola affinché il pezzo W sia fissato in maniera adeguata.
Visser la vis jusqu'au fond du filetage de manière à bloquer complètement la pièces W.
Apriete el tornillo Allen hasta que la pieza W esté fijado de manera adecuada.
Tighten the Allen screw until the component W is fixed in the appropriate way.
Înfiletați șurubul cu cap hexagonal astfel încât piesa W să fie fixată în mod adecvat.
Schrauben Sie die Inbusschraube, so dass das Stück W ausreichend gesichert ist.

